









TOUR À MÉTAUX METAL LATH

550 W



TOUR À MÉTAUX METAL LATHE		GB 550S
Gencode		3431541142503
	Puissance du moteur Motor power	550 W 230V ~ 50Hz
	Vitesses Speeds	X 6 140 - 1710 min ⁻¹
	Mandrin autoserrant Keyless chuck	
	Poids Weight	124,50 kg
	Capacité du mandrin du tour Metal lathe chuck capacity	ø 100 mm
A	Entrepointes Distance between centre	550 mm
B	Hauteur de pointe sur le banc Height of center over bed	110 mm
	Filetage métrique Metric threading	0,4 - 3 mm
	Filetage Anglais Withworth threading	8-28 TPI
	Changement de vitesse Gear selection	Selecteur Selector
	Dimensions de la table Table sizes	-
C	Hauteur de pointe sur le chariot Height of center over carriage	65 mm
D	Course du chariot longitudinale Longitudinal travel	350 mm
E	Course du chariot transversale Cross travel	115 mm
F	Capacité int/ext du mandrin de tournage Turning chuck ins/outside capacity	F1= 3-90 mm F2= 30-80 mm
G	Cône morse de la poupée fixe Spindle bore	CM3 MT3
H	Cône morse de la poupée mobile Morse taper of hole in tailstock	CM2 MT2
I	Passage de broche de tournage Spindle bore	20 mm

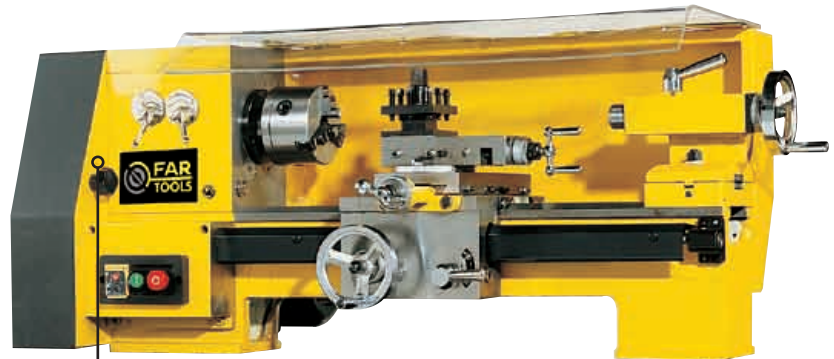

Boîte de vitesses
Gear box

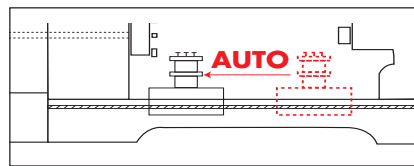

Avance automatique du chariot
longitudinal
Feeding speed of the longitudinal carriage

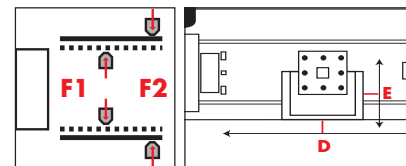

Mors intérieur et extérieur
Inside and outside jaws

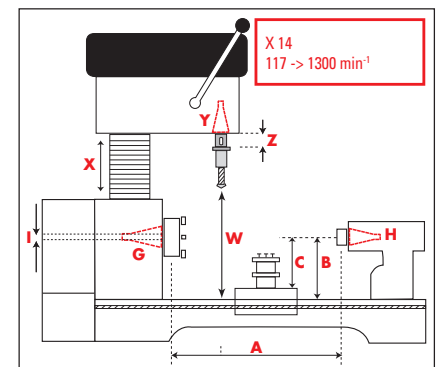

Livré avec un jeu de pignons pour filetage métrique et Anglais, 2 pointes sèches, un mandrin de tournage 100 mm avec mors intérieurs et extérieurs. Dimensions hors tout : 920x480x470 mm

Delivered with a set of metric and withworth threading pinions, 2 center points, one 100 mm turning chuck with inside and outside jaws. Overall sizes: 920x480x470 mm